A large-scale industrial facility, likely an oil and gas refinery, is shown at night. The scene is dominated by a complex network of steel structures, including tall distillation columns, a dense web of pipes, and a prominent elevated walkway or bridge structure in the foreground. The entire facility is illuminated by numerous bright lights, creating a stark contrast against the dark night sky. The lighting highlights the intricate details of the industrial architecture and the scale of the operation.

**Solutions for the  
oil and gas industry**

**OBO**  
BETTERMANN

**THINK CONNECTED.**



# Solutions for the oil and gas industry

---

Around the world, OBO systems are a benchmark for long-term quality, which also prove themselves under the toughest conditions. To ensure the optimum function of production processes and to protect people and the environment, we can offer more than just individual products to our customers from the oil and gas industry: A wide range of solutions ensures comprehensive electrical equipping of your plants. Robust and durable for decades.

---





# Think connected.

OBO means thinking in networks and acting systematically. We combine our products to produce solutions for your particular project in industry, commerce and infrastructure facilities - worldwide.

---

**Basic principles**

---

**Cable support systems**

---

**Pipe systems**

---

**Rail systems**

---

**Fire protection systems**

---

**Lightning and surge protection systems**



## High loads for the electrical infrastructure

Risk of explosion, surge voltages, extreme temperatures, mechanical influences or aggressive substances endanger the electrical infrastructure and thus the work capacity of industrial plants.

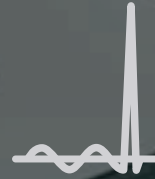

---

Lightning,  
surge voltage,  
electromagnetic  
interference



---

Fire, sparks,  
risk of explosion



---

Mechanical  
loads from  
impacts



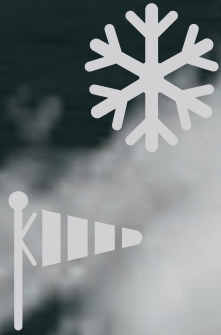

---

Dust, rain, snow,  
wind



---

UV radiation,  
extreme temperatures



---

Salt, corrosion,  
chemical loads



## OBO systems provide continuous protection against high loads

Through the use of matched components, OBO systems offer protection against a wide range of damaging influences. They ensure a perfect flow of power and data,

even under tough conditions. The comprehensive OBO portfolio contains tested, long-life products for every application.



Cable support systems



Function maintenance systems

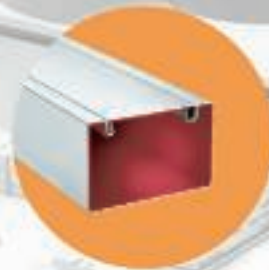

Fire protection systems



External lightning protection and earthing systems



Surge protection systems



Rail systems



Pipe systems



## International competence. On-site.

### Certified safety

OBO solutions ensure continued fault-free processes in buildings and systems of the gas and oil industry. Our high-quality range of products and services is globally certified and fulfils all the key international standards. This simplifies the planning and execution of deployments around the world and ensures cost optimisation. Efficient processes at OBO ensure that pro-

ducts are available at the right time. It doesn't matter where our customers are erecting or operating systems.

### Decades of experience with major projects

When the building size and the challenge of use increases, the complexity of the electrical infrastructure also increases. For decades, our electrical systems have

contributed to the success of major projects. The comprehensive product range, with different surfaces and materials, permits precise matching to the appropriate deployment location. Our customers can profit from the matching service process, which stretches from project planning through to delivery and consultation on the construction site.

- Production location
- Subsidiary
- Representative



### Excerpt from our reference list

- INA oil refinery Rijeka, Croatia
- Oil refinery, Serbia
- OMV oil refinery, Romania
- Vankor oil field, Russia
- OAO Taneco oil refinery, Niznekamsk, Russia
- Oil refinery, Saratov, Russia
- Oil refinery, Tomsk, Russia
- Berezovsk oil refinery, Berezovsky, Russia
- Krasnoleninsky oil refinery, Nyagan, Russia
- Oil pumping station, Mukhanovo, Russia
- Coral gas processing plant, Ulyanovsk, Russia
- Gazprom gas processing plant, Sosnogorsk, Russia
- Neftegorsk gas processing plant, Russia
- Komsomolsky Feld gas pressurisation station, Russia
- Agrolinz - Melamine chemicals works, Piesterlitz, Austria
- Roche research, development and production centre, Penzberg, Germany
- Schering pharmaceutical plant, Bergkamen, Germany
- Degussa petrochemical plant, Herne, Germany
- Lantus industrial park, Frankfurt Höchst, Germany
- Linde AG Elektronik Gase, Unterschleissheim, Germany
- Chemiewerk BCA Bitterfeld Chlor-Alkali GmbH, Bitterfeld, Germany
- Boehringer Ingelheim Pharma, Biederach, Germany
- Petrolen chemical works, Philippines
- Raylen IV chemical works, Thailand
- Raylen polypropylene, Thailand
- Navoi chlorine-alkali electrolysis, Uzbekistan





**We can make it easy. [www.obo-construct.com](http://www.obo-construct.com)**

We want to make it as easy as possible for you to select and configure our systems. To do this, we have bundled our electronic planning aids in the Construct portal. The following modules are available at [www.obo-construct.com](http://www.obo-construct.com):

**AutoCAD planning tool, cable support systems**

**Online planning tool, cable support systems**

**Software, cable assignment, cable support systems**

**Online configurator, insulation systems**

**Online configurator, surge protection systems**



## Strong innovative force



### **Certified brand quality**

Innovative drive is an elementary part of OBO's corporate history. Five to ten per cent of the overall group turnover flows into research and development. Thanks to in-house production in the fields of metals, plastics and electronics, we can reach a very high level of

production. This gives us control over the whole creation process of a product. The certified brand quality of the OBO products is designed for continuous top performance. We have stood for this quality for more than 100 years as a family company.





## Tested quality



### BET Test Centre

At our in-house BET Test Centre, we can simulate the loads our products must withstand over the years. For all the OBO cable support systems, we determine the maximum load capacity according

to support spacings and specific parameters. In the salt spray test, all the system components must show sufficient resistance to corrosion, in accordance with the KTS standard DIN EN 61537. In addition, lightning protection experts in the BET Test Centre perform stan-

dardised tests on OBO lightning and surge protection components, lightning protection structures and surge voltage protection units. A wide range of different testing methods guarantees the high level of safety of OBO products.

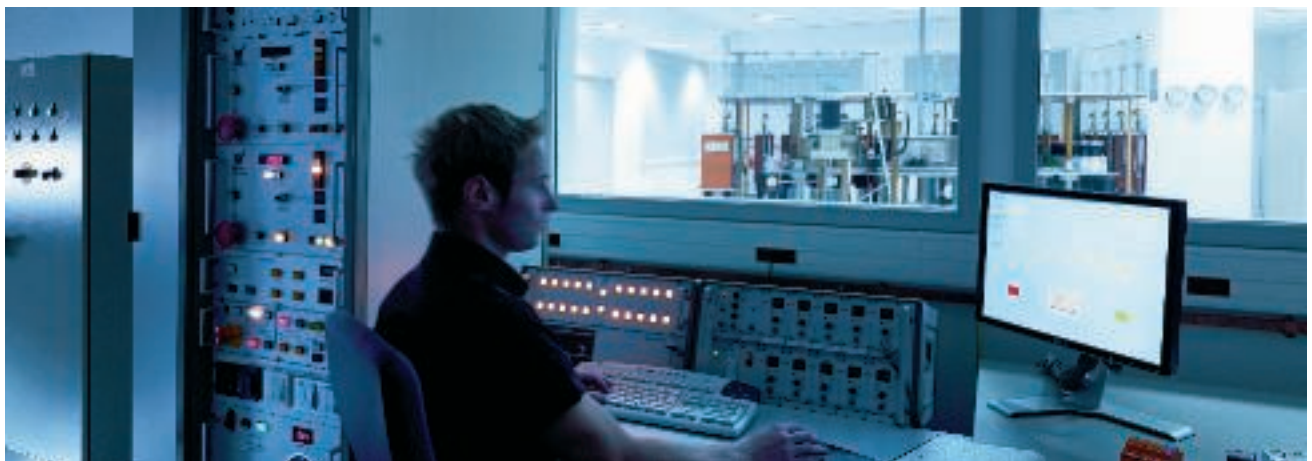

Lightning current generator in the BET Test Centre





### Standardised tests in the BET

- Lightning protection components to EN 50164-1
- Spark gaps to EN 50164-3
- Surge protection devices to EN 61643-11
- Data cable protection devices to EN 61643-21
- Cable support systems to EN 61537
- Electrical installation duct systems to EN 50085-1
- Connection sockets and housings to EN 60670-1 and -22
- Environmental testing to EN ISO 9227 (neutral continuous salt spray testing)
- Environmental testing to EN 60068-2-52 (cyclical salt spray testing), environmental testing to EN ISO 6988 (SO<sub>2</sub> corrosive gas testing)
- Protection rating to EN 60592
- Tensile strength to EN 10002-1



Salt mist spray test



Load test in the BET Test Centre

# Proper corrosion protection







## Corrosion categories

Corrosion can lead to high loss levels or even the failure of technical systems. For this reason, the prevention or reduction of corrosion is an important part of the protective measures on steel components. The corrosion categories are defined exactly in DIN EN ISO 12944-2. The standard assigns the am-

bient atmospheric conditions to a total of six different categories. The following parameters determine the strength of the corrosion and the speed at which it is occurring:

- The relative humidity
- The risk of dew formation
- The concentration of impurities promoting corrosion

## Corrosion categories to DIN EN ISO 12944



			
Corrosion category	C1	C2	C3
Average zinc removal	< 0.1 µm/a Insignificant	0.1 to 0.7 µm/a Low	0.7 to 2.1 µm/a Medium
Typical environment, inside	Heating buildings with neutral atmospheres, e.g. offices, shops, schools, hotels	Unheated buildings in which condensation can occur, e.g. warehouses, sports halls	Production facilities with a high level of humidity and some air impurities, e.g. plants for food production, laundries, breweries, dairies
Typical environment, outside	-	Atmosphere with low level of impurities. Usually rural areas	City and industrial atmosphere, considerable impurities through sulphur dioxide, coastal areas with low salt load
OBO desktop	Electrogalvanisation <ul style="list-style-type: none"> <li>• Electrolytic galvanisation according to DIN EN 12329</li> <li>• Average layer thickness approx. 2.5-10 ¼µm</li> <li>• According to RoHS directive</li> </ul> Typical components: Mesh cable trays and small parts such as bolts, washers and nuts	Strip galvanisation <ul style="list-style-type: none"> <li>• Hot galvanisation using the strip galvanisation method according to DIN EN 10327 (formerly DIN EN 10147 and DIN EN 10142)</li> <li>• Average layer thickness approx. 20 µm</li> <li>• Plate interfaces are protected by the cathodic corrosion protection up to a material thickness of 2.0 mm</li> </ul> Typical components: Metal products, such as cable trays, fittings and separating retainers	Hot-dip galvanisation <ul style="list-style-type: none"> <li>• Hot galvanisation using the hot-dip method according to DIN EN ISO 1461</li> <li>• Layer thickness according to DIN EN ISO 1461 approx. 40-60 µm</li> <li>• Interfaces created at a later date must be re-galvanised to ensure corrosion protection</li> </ul> Typical components: Metal products such as lids, separating retainers and punched parts
OBO pictogram			



### Special requirements

The lifespan of a cable routing system is dependent upon the environment in which it is located. The highest levels of material quality and corrosion protection are always required when cable support systems are installed outdoors. In particular, deployment in aggressive atmospheres, such as those in

the chemicals or petrochemical industries, is a particular challenge. The systems are also subjected to permanent loads under extreme weather conditions, or when close to the sea. It is therefore extremely important to know the environmental influences when selecting the right material and the necessary surface treatment.

		
C4	C5-I	Cs-M
2-4 µm/a Strong	4-8 µm/a Very strong (Industry)	4-8 µm/a Very strong (Sea)
Chemical plants, swimming pools, boat sheds over seawater	Buildings or areas with almost continuous condensation and with high levels of impurities	Buildings or areas with almost constant condensation and high levels of impurities
Industrial areas and coastal areas with low salt load	Industrial areas with high levels of humidity and aggressive atmosphere	Coasts or offshore areas with salt load
Strip galvanisation or hot-dip galvanisation with additional powder coating	V2A stainless steel <ul style="list-style-type: none"> <li>• OBO short code: V2A</li> <li>• European material number 1.4301</li> <li>• American material designation 304</li> <li>• Welded components are additional passivated</li> <li>• Unwelded components are rinsed and degreased</li> </ul>	V4A stainless steel <ul style="list-style-type: none"> <li>• OBO short code: V4A</li> <li>• European material number 1.4571/1.4529/1.4547</li> <li>• American material designation 316 / 316 T</li> <li>• Welded components are additional passivated</li> <li>• Unwelded components are rinsed and degreased</li> </ul>
<div style="display: flex; gap: 10px;"> <span style="background-color: yellow; padding: 2px;">FS</span> <span style="background-color: orange; padding: 2px;">P</span> <span style="background-color: lightblue; padding: 2px;">FT</span> <span style="background-color: orange; padding: 2px;">P</span> </div>	V2A	V4A V5A

## Explosion protection and ATEX directives

Every year, explosions endanger people and systems around the world. Any company manufacturing, processing or storing combustible substances must expect possible explosions. Levels of injury and damage to people and property running into the millions of

euros will occur, because companies stunted on safety mechanisms. Combustible and explosive substances can occur in the form of gases, vapours, mists or dusts. In particular, in the petrochemical industry and the conveyance of crude oil and natural gas, explosions

can cause major damage to people and equipment. Explosion protection will prevent damage to technical products, systems and other equipment.

---

### The three basic principles of explosion protection

- Avoid potentially explosive atmospheres
- Avoid any possibly effective source of ignition
- Limit possible explosion impacts to a reasonable level through structural measures

---

### Three factors must exist for an explosion to occur

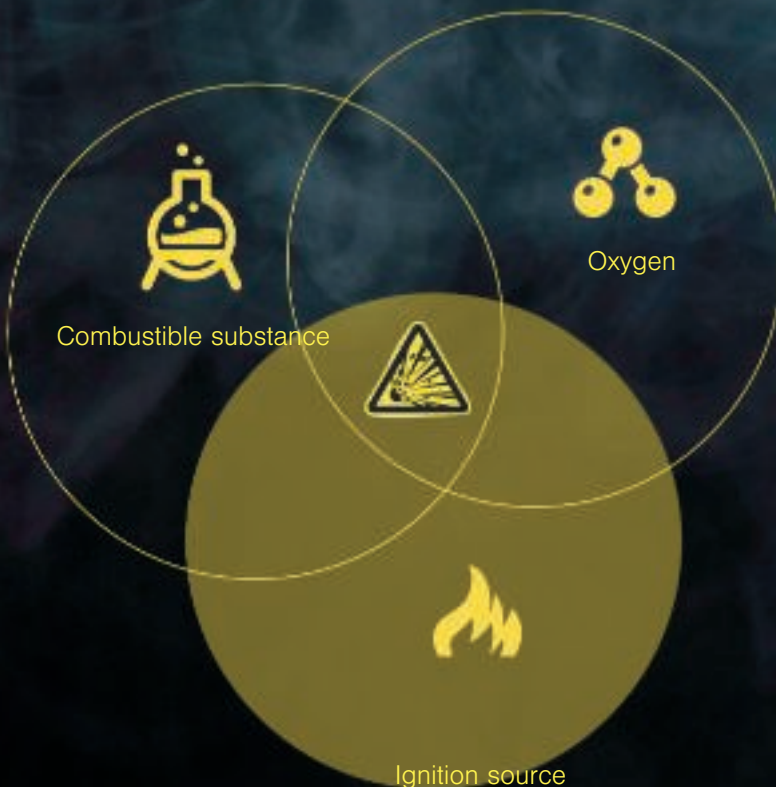

---

### Ignition protection types

- Encapsulation
- Intrinsic safety
- Increased safety





### Tricky: Systems in potentially explosive areas

Special precautions are necessary when setting up systems in areas with the risk of a potential explosion. Special requirements also apply to cables. The operator divides up areas, in which potentially explosive atmospheres may occur, into zones. They ensure that the minimum requirements are applied. They must also indicate access points to potentially explosive areas.

### Atmosphères Explosibles: ATEX/EX

The term ATEX is derived from the French words **AT**mosphères **EX**plosibles. The EU ATEX directives regulate the requirements resulting from the use of devices and protection systems in potentially explosive areas. Due to increasing international economic intermeshing, major progress has been achieved in the standardisation of the explosion protection regulations. In the European Union, the preconditions for complete standardisation were created in the directives 94/9/EC for manufacturers and 99/92/EC for operators.

### Manufacturer directive 94/9/EC (ATEX 95)

The directive regulates the requirements for the structure of explosion-protected devices and protection systems, by prescribing basic health and safety requirements.

Manufacturers of components for potentially explosive areas must obtain an approval for their products. The quality requirements for the production of resources without effective sources of ignition is extremely high. An approved test office will only certify the function of the components of a manufacturer after a comprehensive test, and will assign them into categories according to failure safety.

---

#### Certified by

- DEKRA (ATEX)
- DNV
- Fieldbus Foundation



## Maximum variety for your project

Systems with different materials and surfaces give you maximum freedom when planning and executing a project.

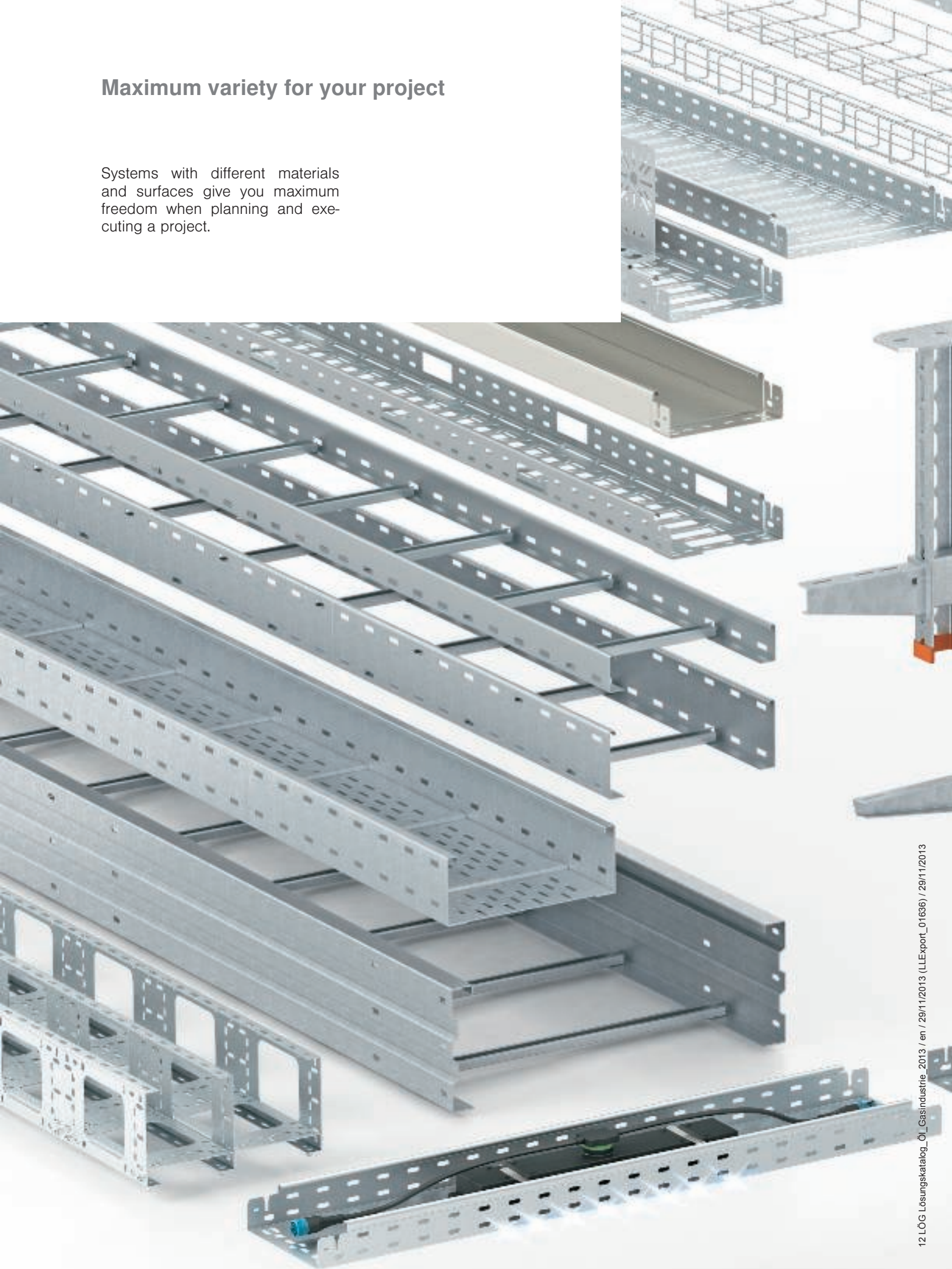



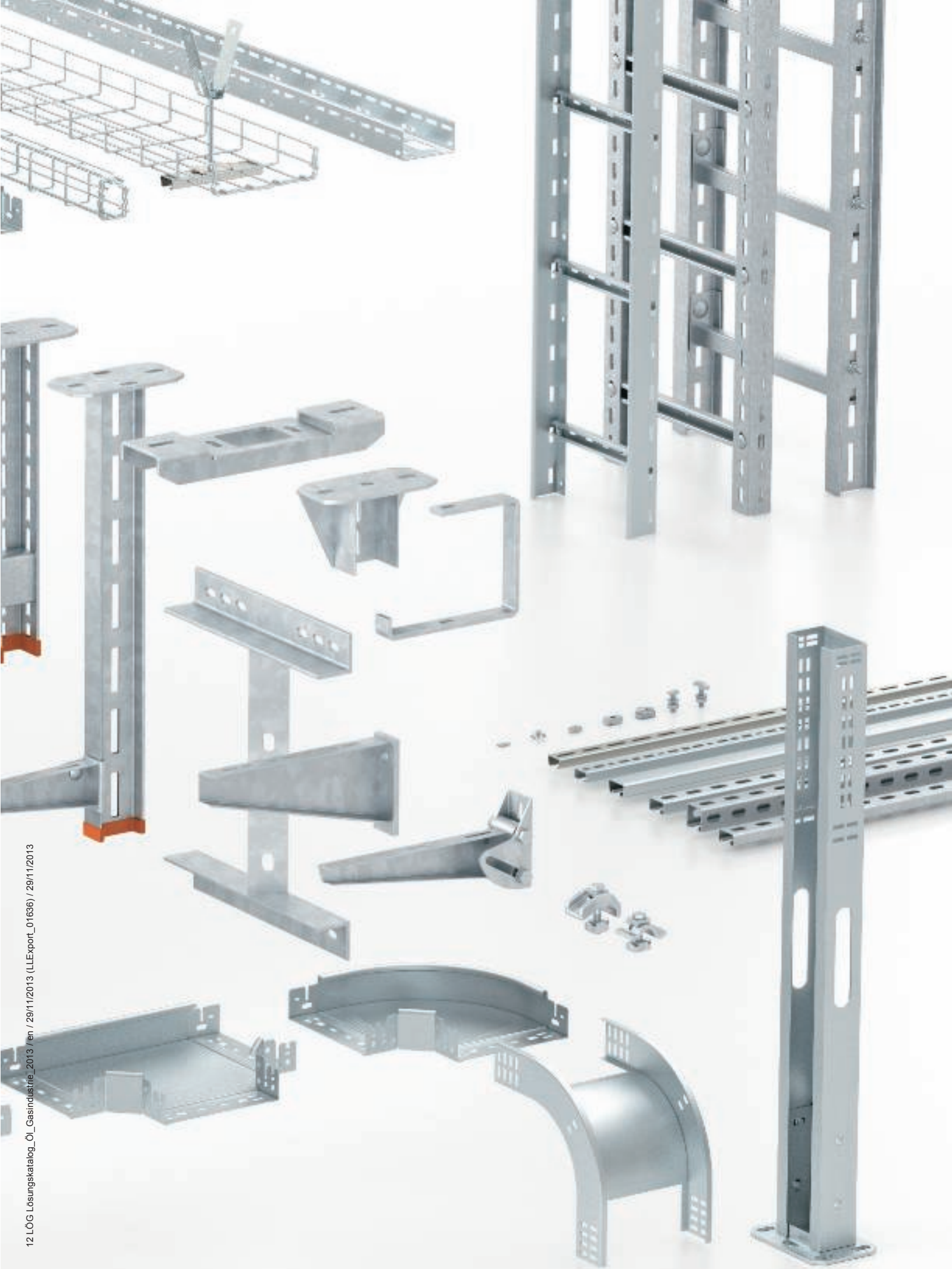

## Cable ladder and ladder systems

### Cable routing under extreme conditions

OBO cable routing systems can beat aggressive atmospheres and extreme weather conditions. They are the right solution for tackling wide support spacings and high

loads. OBO cable ladders and rising sections are supplied complete with mounting systems for reliable fastening. With their high load capacity and good ventilation properties, they ensure safe cable routing in gas or oil conveying

plants. OBO cable support systems are tested according to all the relevant international standards. They can also prove their reliability every day in the chemical and petrochemical industry.

---

### Available materials and surfaces

- Hot-dip galvanisation according to DIN EN ISO 1461
- Galvanisation with different layer thicknesses
- Version with additional coloured plastic coating
- Stainless steel versions

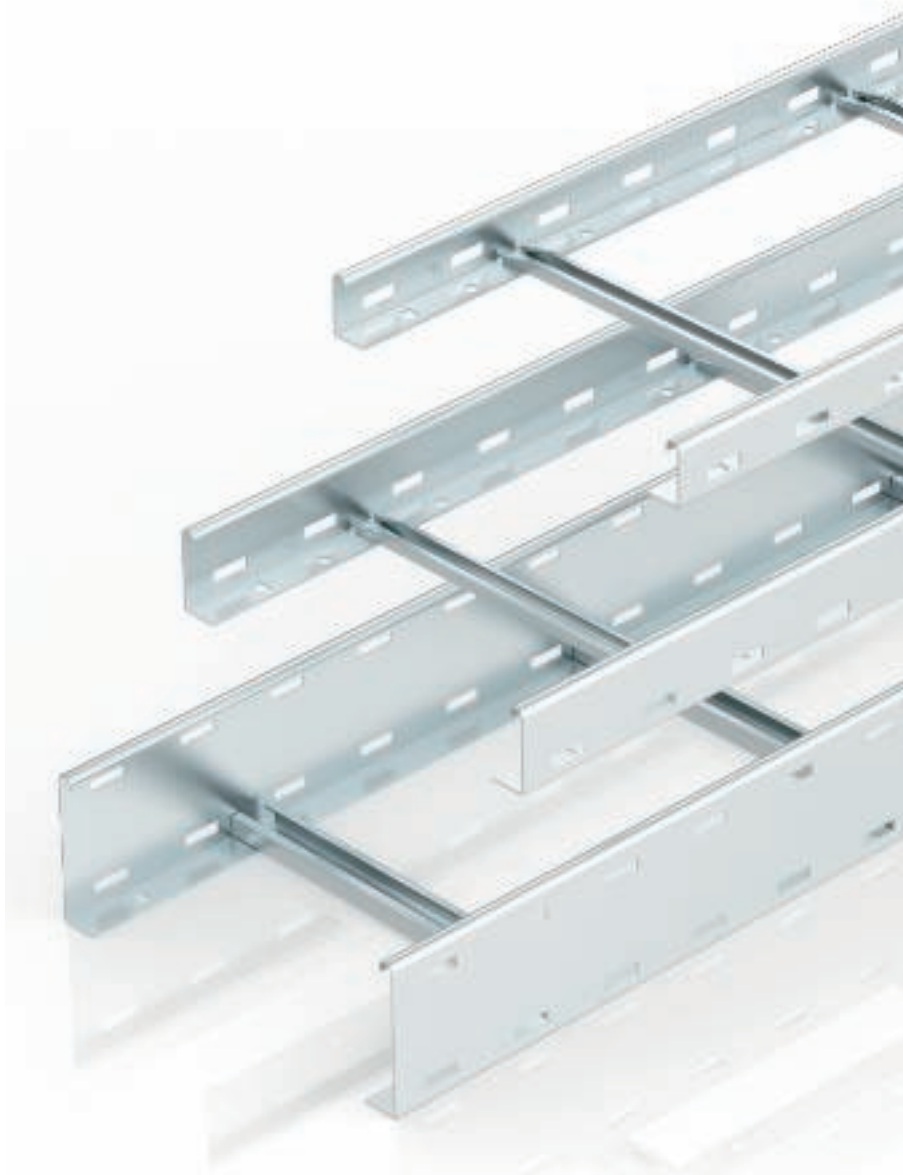



---

**Certified by**

- VDE
- IEC
- GOST
- UL/CSA

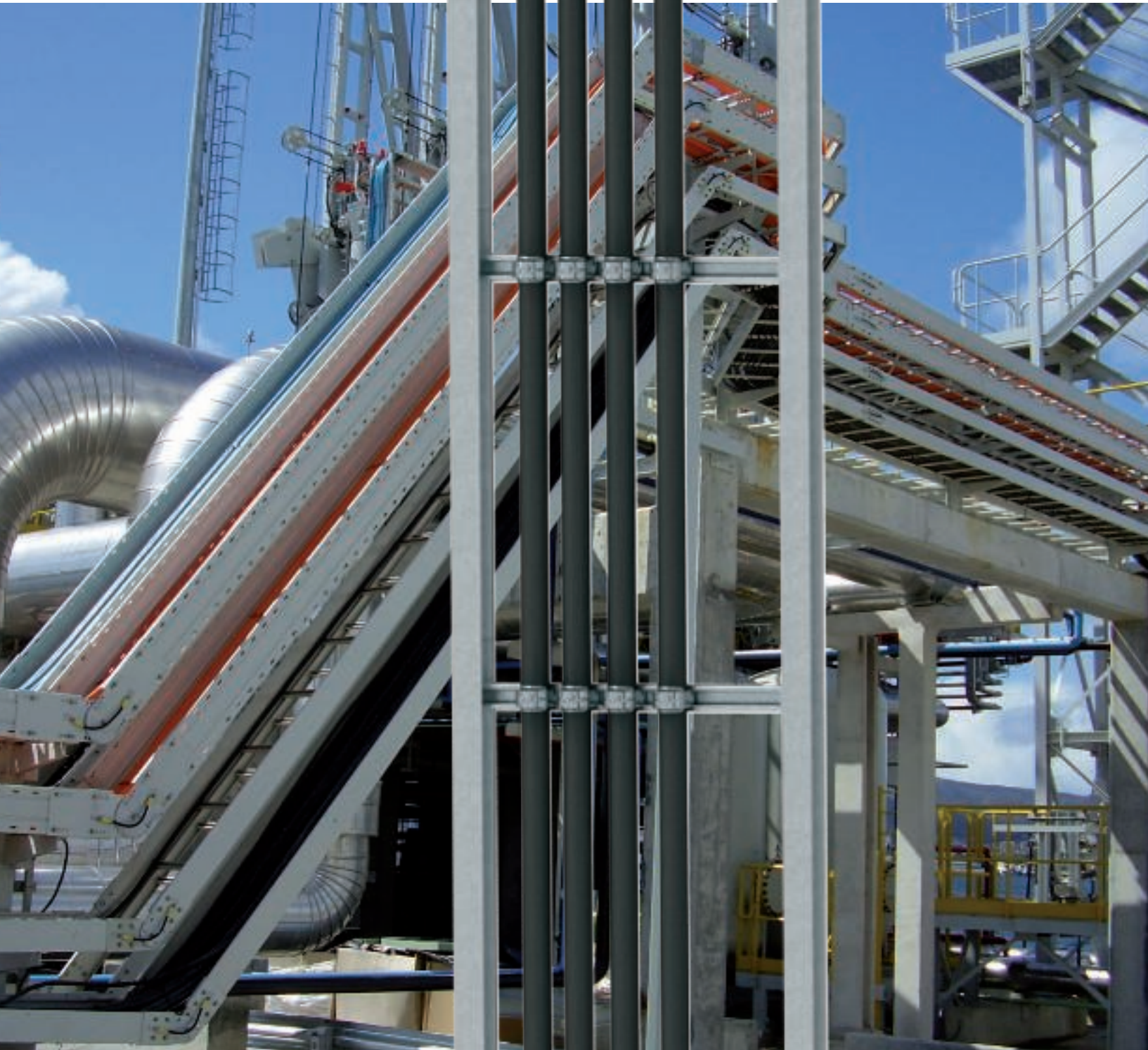



## Wide span systems



### **For long distances and high loads**

OBO also has the right cable support system for special tasks. Wide span systems are used to bridge large gaps and high cable loads.

### **High load capacity**

OBO systems have proven their worth in many areas of industrial and systems engineering. The product range contains versions with various dimensions and surface executions. In addition, OBO can offer a comprehensive range of system accessories, such as fittings and fastening materials.







## Cable tray systems and mesh cable tray systems

### Speed and safety

With their innovative connection system, OBO cable trays and mesh cable trays combine speed, load capacity and safety. Just connect the pieces, lock them in place – and you're done.

### Varied systems

As one of the leading manufacturers of cable support systems, OBO can offer a broad spectrum of innovative products: Besides the universal RKS-Magic® cable tray with a classic base structure, the cable trays of type SKS-Magic®, MKS-Magic® and IKS-Magic® mean there are completely new systems in the product range. Variable bends and fitting conductors allow quick and flexible connections when installing cable support systems, even in the tightest of spots.

### EMC protection and equipotential bonding

With their lid, OBO cable support systems offer shield attenuation of approx. 50 dB, which can repel almost any electromagnetic interference pulses. Without the lid, the attenuation level is up to 20 dB. The systems fulfil the equipotential bonding requirements of IEC 61537.

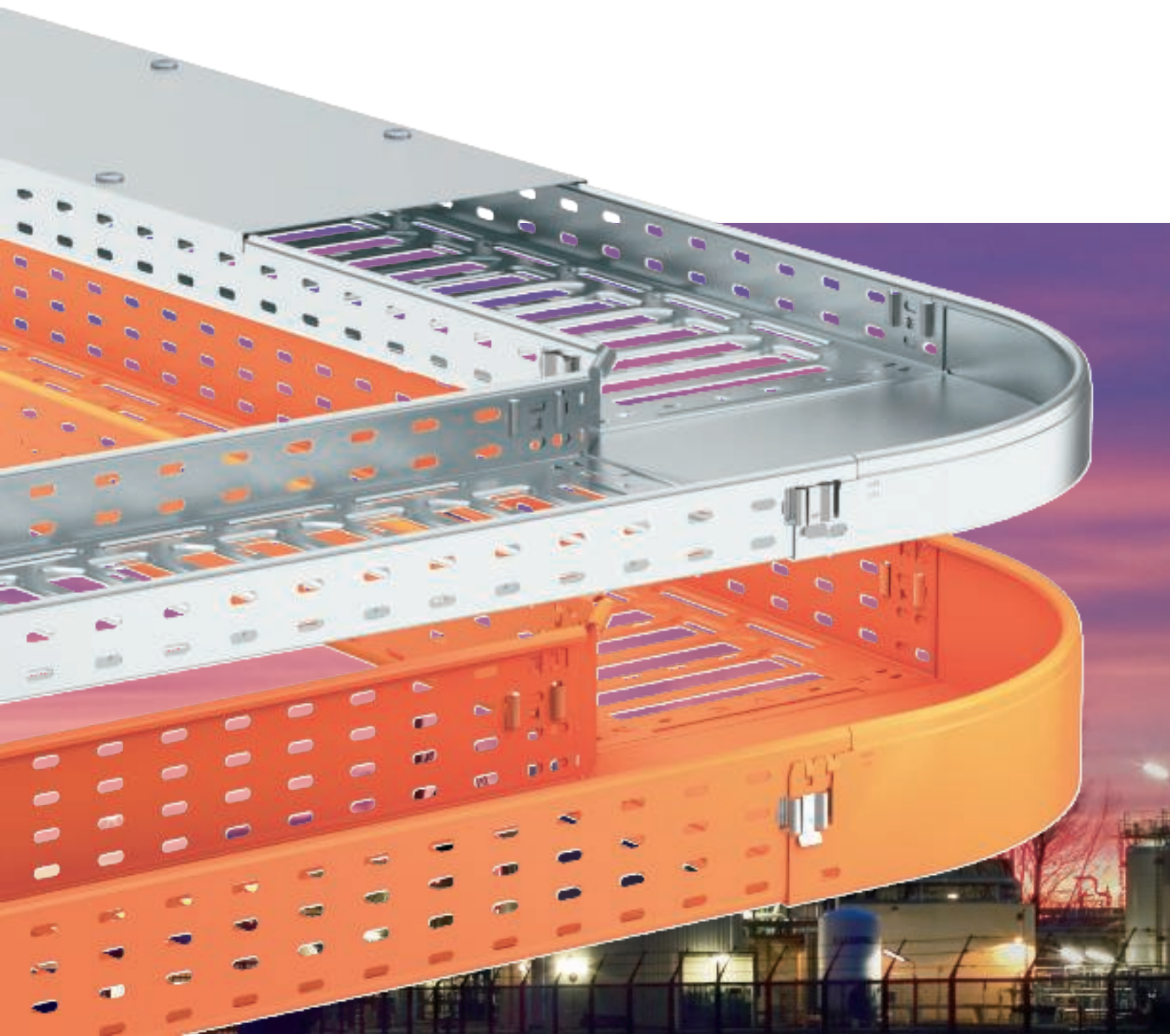



---

**Certified by**

- VDE
- GOST
- UL
- BET (EMC Testing)

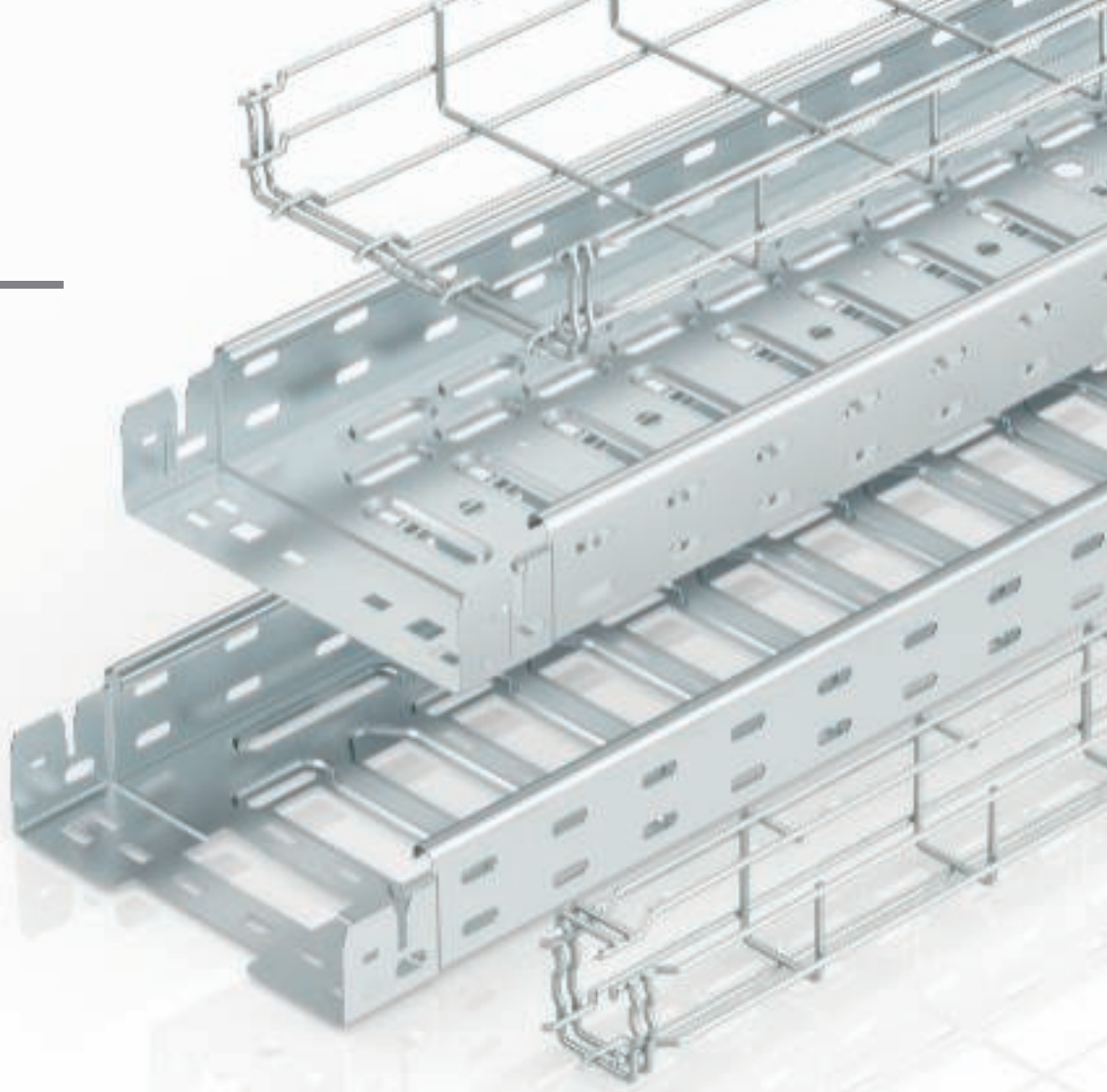

---

**Available materials and surfaces**

- Hot-dip galvanisation according to DIN EN ISO 1461
- Galvanisation with different layer thicknesses
- Version with additional coloured plastic coating
- Stainless steel versions



## Function maintenance systems

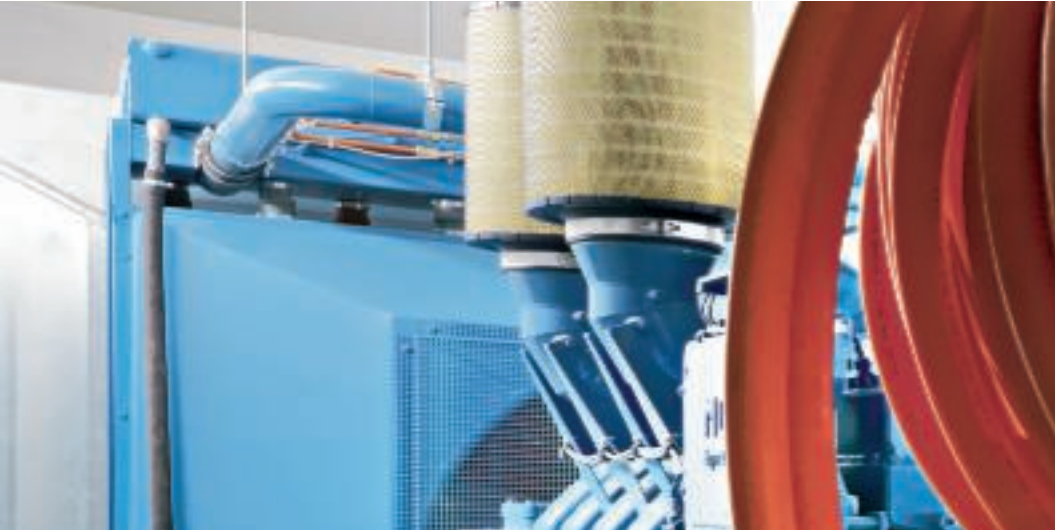

### Valuable time can be won for safety-relevant electrical systems

Petrochemical and chemical plants place the highest requirements on the quality and reliability of the installed systems. This is particularly important in the case of a fire. The function maintenance of electrical systems is one of the central measures required by building laws for the protection of people, buildings and systems. Function maintenance is considered as the continuation of current flow for a defined period of time during a fire. This won time could save lives, as emergency and escape routes can be used for longer.

### Function maintenance systems

OBO systems for cable systems with E30 to E90 function maintenance are tested according to all the key national and international standards. They open up a unique range of cable routing options and ensure that safety-relevant systems continue to function reliably over a defined period of time in the case of fire. This allows emergency lighting, fire alarm systems or smoke extraction systems to remain active. The longer these safety-relevant systems work, the greater the chances of rescue and fire-fighting are.

---

### Tested according to

- DIN 4102







## Function maintenance systems

### Robust, reliable systems

The planners and operators of industrial plants of any size can rely on the high material quality and installation security of all the components of the OBO function maintenance systems. Surfaces and materials with a high load capacity form a complete product range for practically any application. As they are tested according to DIN 4102

Part 12, they can offer reliable protection. The robust structure of the OBO products can also stand up to other potentially destructive loads. Our systems can withstand corrosion, extreme temperatures, soiling and chemical and mechanical impacts. They can assume important protection functions to ensure a long lifespan for industrial buildings and plants.



12\_LÖG... 01\_Gasindustrie\_2013... / en / 2013 / 01 / 2013 / 01 / 2013



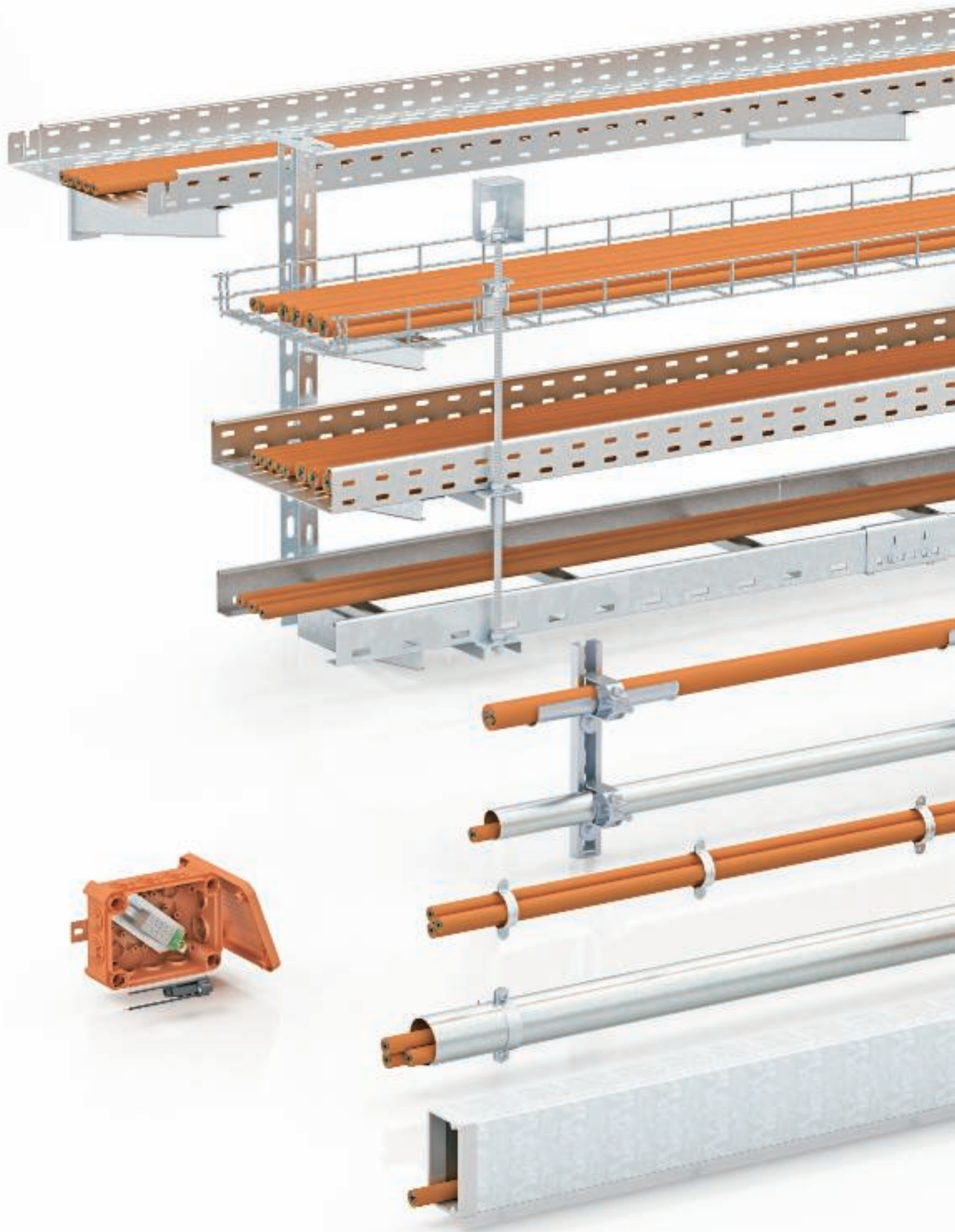

## OBO pipes, fastening clips and rails for individual routing

### Maximum protection of cables in an industrial environment

Cables in industrial environments must be protected against corrosion, chemicals and mechanical loads. Our product range offers the ideal surface and material versions for every requirement. These include junction boxes, glands, clips, pipes, clamp clips and rails, as well as robust plastic or sheet steel cable ducts. Different tempering or coating methods ensure tailor-made corrosion protection to match the application.

### Protection against mechanical loads

When used in the oil and gas industry, OBO metal pipes reliably protect cables against mechanical loads. From galvanised to painted, different material and surface qualities can offer perfect adaptation to the requirements of the appropriate environment.

### The Mx series - developed for use under the toughest conditions

The aluminium housings of the OBO Mx series can even withstand enormous loads. They can beat extremely high and low temperatures and also major differences in temperature. The housing can protect the installation securely against hard impact loads in industrial environments. In addition, the Mx series also offers a high level of EMC protection. The protection rating of IP 66 offers reliable protection against the ingress of dust and water.





H12 F10



## Rail systems

### Flexible, quick and efficient

With their high load capacity, OBO mounting and profile rail systems are an essential part of many electrical installation applications. When combined with the mounting accessories, they allow the creation of various support structures for both indoor and outdoor areas. OBO rail systems can be shortened individually. They can be mounted simply and quickly, without the need for welding or drilling.

### Single and double versions

The profile and mounting rails MS21 and MS41 are available in single and double versions. They offer variety, in the form of the perforated and unperforated variants, curved rails and with slot widths of 7.5 to 22 millimetres. The OBO supply range comprises hot galvanised and sendzimir galvanised rails, as well as stainless steel rails.

### Comprehensive accessories

The OBO profile and mounting rail product range is perfectly complemented with practical accessories. These include connection sections and fastening clips, as well as nuts and bolts to match the system. The comprehensive range of accessories extends the application options of the OBO rail systems and can hold its own, even under the toughest application conditions.





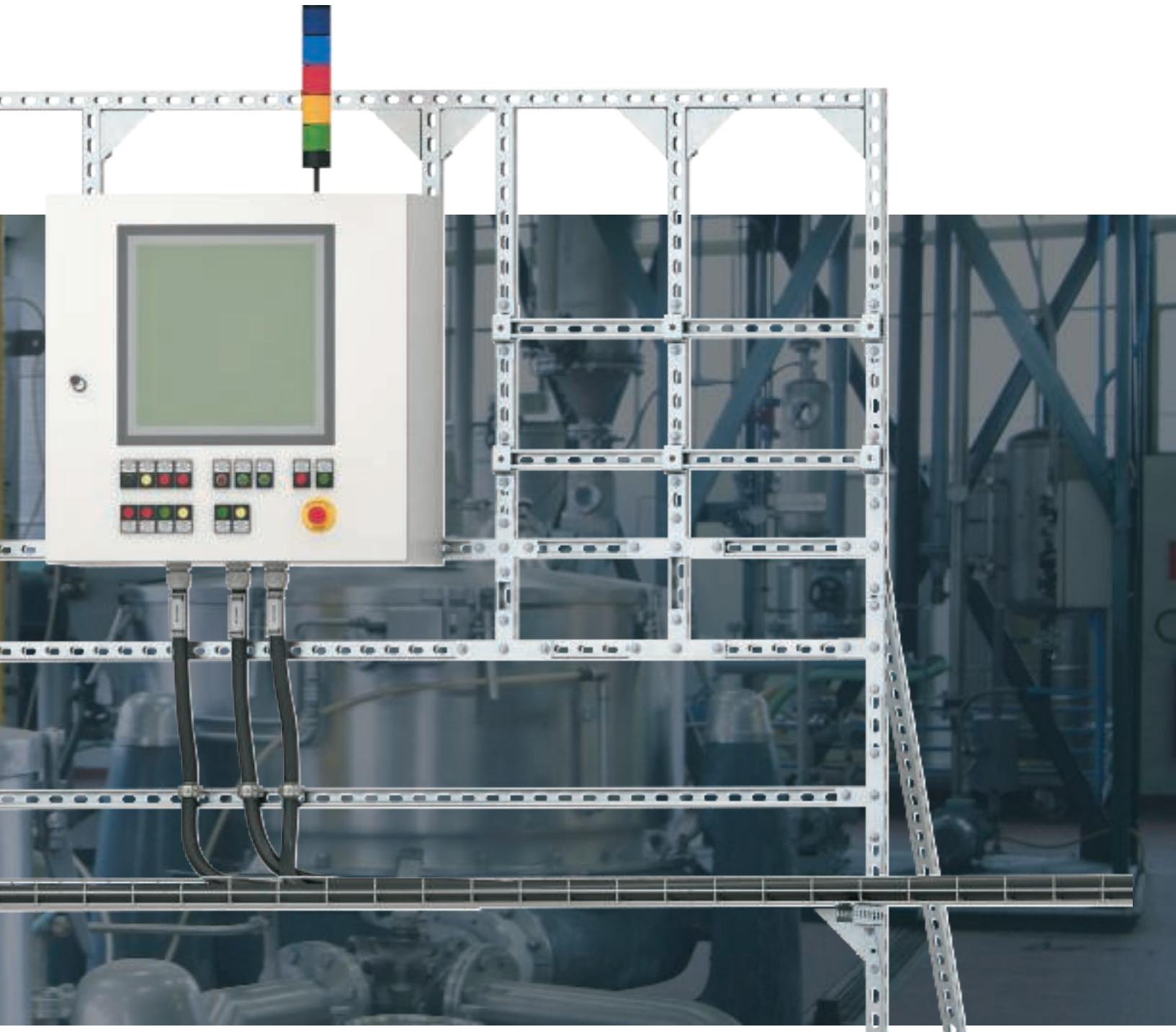



## Insulation systems

### Maintaining fire sections

The limitation of the fire to specific structural sections means that the remaining parts of the building are protected for a defined period of time. This offers valuable extra time for the evacuation of people and the initiation of extinguishing measures. OBO insulation maintains the fire sections, thus preventing a rapid spread of fire and smoke.

### Variety

The insulation is designed for different wall types and the cables or pipes routed therein. In structures, cable systems are arranged in such a way that fire sections with manageable dimensions are created. For this, cable bandages are ideal for surrounding cables. They protect the environment against a cable fire, as the coating foams up if there is a short-circuit, suffocating the fire. If there is a fire on the outside, the bandages ensure that the cables are kept apart from the fire.

---

### Tested according to

- DIN 4102







## Escape route installation systems

### Maintaining emergency and escape routes

When a fire breaks out, every minute is crucial. If there is a fire, emergency and escape routes are the central lifelines of a building. The longer people can use them, the greater the chances that they will escape the fire and dangerous smoke. It is therefore mandatory to have at least one structural emergency and escape route in any building, and, in industrial buildings, more may even be required. OBO can offer two installation solutions for the protection of emergency and escape routes.

### False ceiling systems

Tested false ceiling systems are suitable for use beneath suspended fire protection ceilings. Even if there is a fire in the cables installed there, the emergency and escape route can still be used.



---

### Tested according to

- DIN 4102

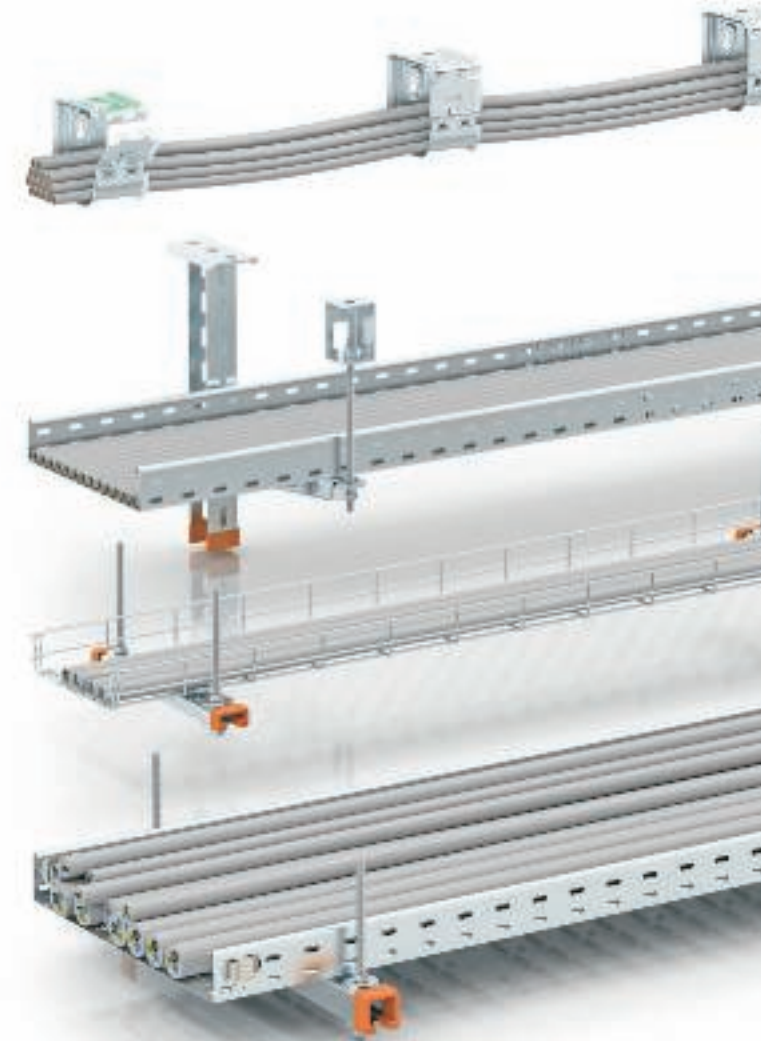





### Fire protection ducts

Metal fire protection ducts with an intumescent inner coating or fibre-glass-reinforced light concrete can protect emergency and escape routes against the effects of a cable fire, during which a lot of dense, black smoke is created.

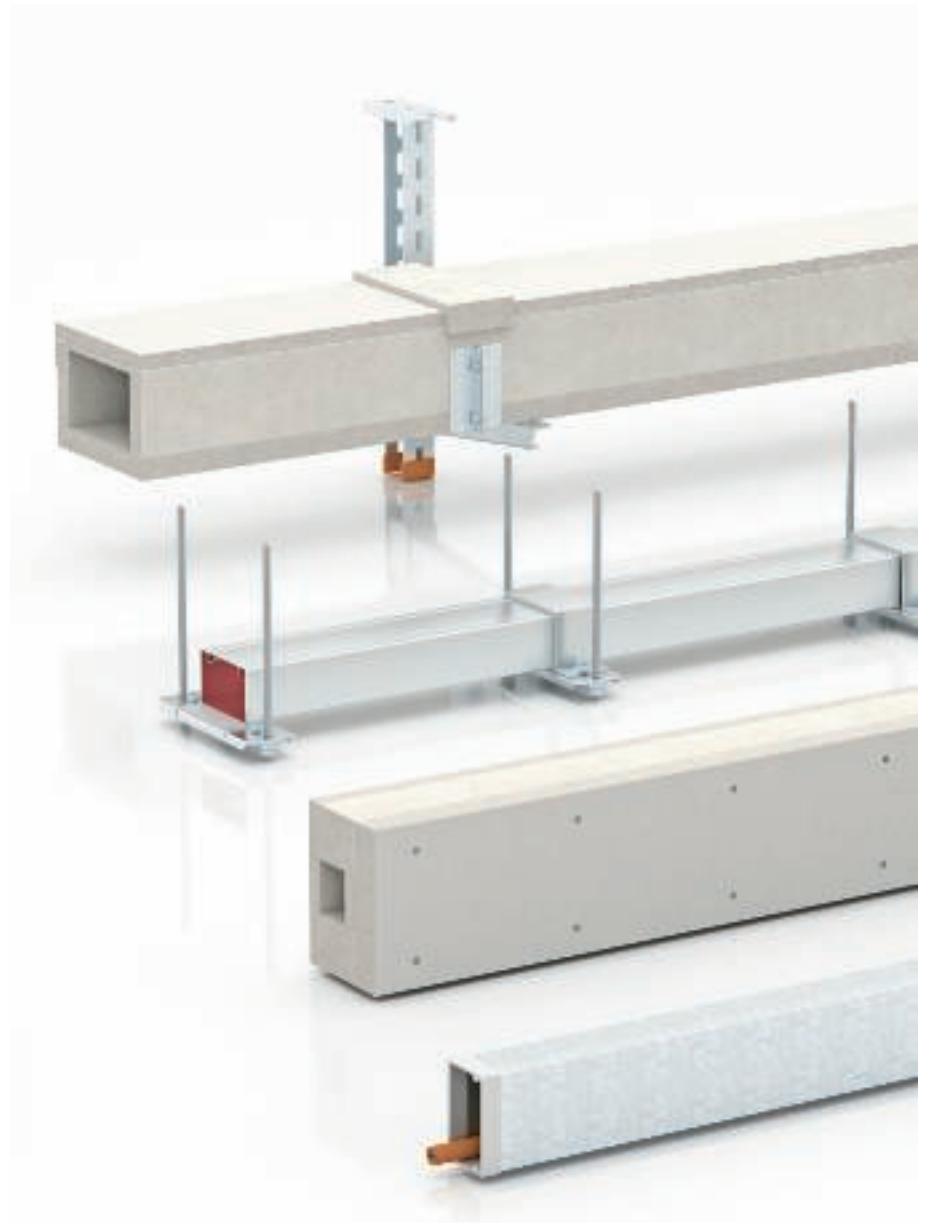

## Air termination and down conductor systems

### Air-termination systems

Direct and indirect impacts of lightning strikes and other transient surge voltages can endanger chemical and petrochemical plants. According to the ATEX directives, the operators are responsible for the safety of their plant. They must carry out the zone assignment and evaluate explosion risks. OBO can offer the right air-termination and arrester system for every application.

### Tested safety

The lightning protection components fulfil IEC 62305 (VDE 0185-305) and have been tested according to the international and European standards IEC 62561 (VDE 0185-561). They adopt important protective functions in potentially explosive areas of petrochemical plants, tank warehouses or power stations. Chimneys, antenna masts, ventilation pipes, tanks and similar parts of the system can be protected using separated and isolated interception rods.







### Down conductor systems

From the air-termination systems, insulated arrestors carry the lightning current safely and without sparks on or in parts of the plant, from the impact point to the earthing systems. This means that people and plants are equally well protected against the risks of lightning current as against spark formation and the resulting fires. The air termination and down conductor systems must be planned on the basis of the explosion protection zone division. Lightning currents are arrested without ignition sparks along the insulated arrestor OBO isCon®. Through the properties proven through these tests, the isCon® arrestor can be used in potentially explosive areas.

---

#### Tested by

- BET Test Centre
- DEKRA (ATEX)

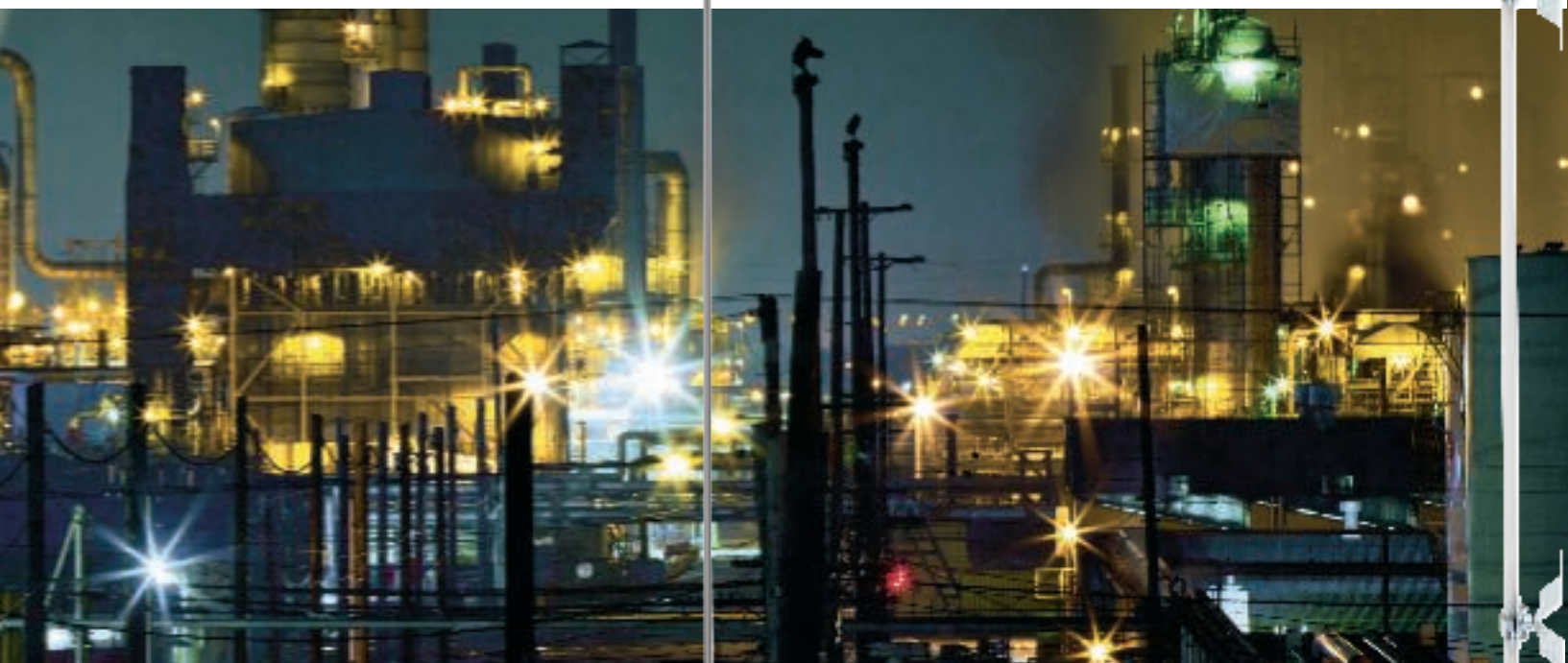

# Earthing systems

## Earthing systems in industrial plants

In industrial plants, the connection of all the available earthing systems forms the basis for fault-free operation. A densely meshed, global earthing network reduces the potential differences to a minimum. The mesh width may vary, depending on the structural system.

## Transfer of the lightning current into the earth

Earthing systems carry the intercepted and arrested lightning current into the earth. In addition, they must avoid potential differences safely. The entire earthing system includes the protective earth to protect people and property, lightning protection earthing to transfer the lightning current into the earth and functional earthing of the electrical system components.

## Mesh widths

A mesh width of 20 x 20 metres is recommended for technical and economical reasons. Above-ground pipe bridges outside production facilities must be connected to an earthing system every 30 metres. OBO has the right, standard-conformant, continuously resistant earthing system for each application, both for lightning protection earthing according to IEC 62305 (VDE 0185-305) and for a foundation earthing system according to DIN 18014.



## Earthing systems

- Components tested according to IEC 62561 (VDE 0185-561)
- Solutions for all earthing types, e.g. foundation, ring, deep and surface earthing
- Systems for all applications, from lightning protection to equipotential bonding





**HINWEIS!**  
Isolierter Blitzschutz mit dem  
OBO isCoE-System.  
Änderungen sind nur von einer  
Blitzschutzfachkraft  
durchzuführen!

## Equipotential bonding systems and spark gaps

### Secure protection against voltage differences

Equipotential bonding systems ensure safe distribution of the lightning energy. However, in the case of other voltage differences, they can protect people and electrical systems and devices in a building against an electric shock. In the case of a lightning strike, about 50 per cent of the lightning energy is arrested into the earthing system. The remaining 50 per cent is distributed on the equipotential bonding system (internal lightning protection). In particular, the sections of the electrical energy distributor and data technology systems must be specially protected.

### Statutory requirements

An equipotential bonding system must be set up in every building, in accordance with IEC 60364 (VDE 0100-534) and IEC 62305 (VDE 0185-305). This is also mandatory in the case of each new installation or modification. With the tested OBO products, meshed state-of-the-art equipotential bonding can be created through the integration of the metallic building components, such as reinforcement rods or metal facades. Thus, optimum protection against potential differences and inductive couplings can be created.

### Equipotential bonding in potentially explosive areas

In areas with a potentially explosive atmosphere, insulated, encapsulated spark gaps with the approval for use in potentially explosive areas must be used for equipotential bonding. The OBO Parex spark gap insulates the parts of the system against corrosion currents, fulfilling the requirements for the connection of lightning currents in potentially explosive areas.

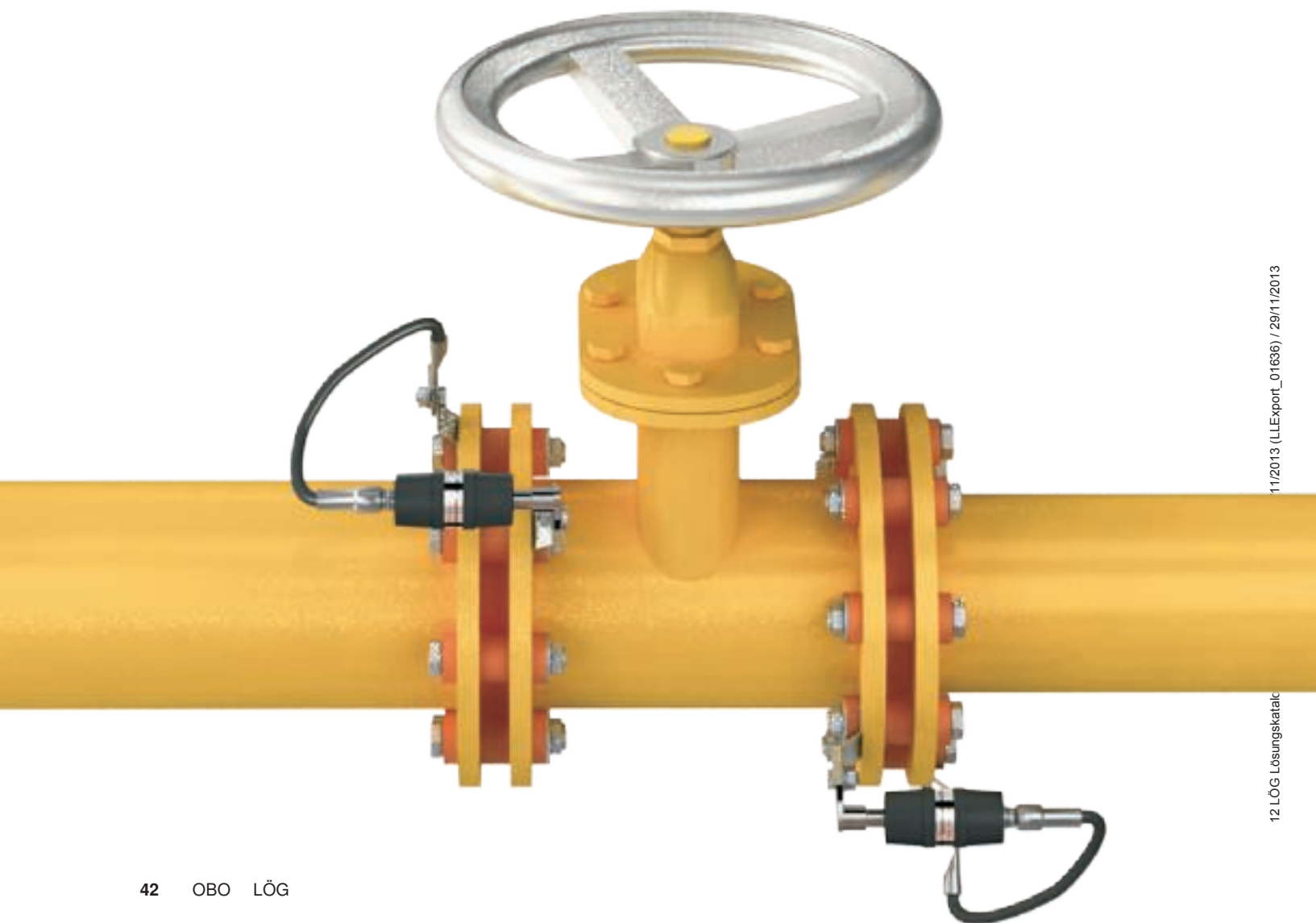



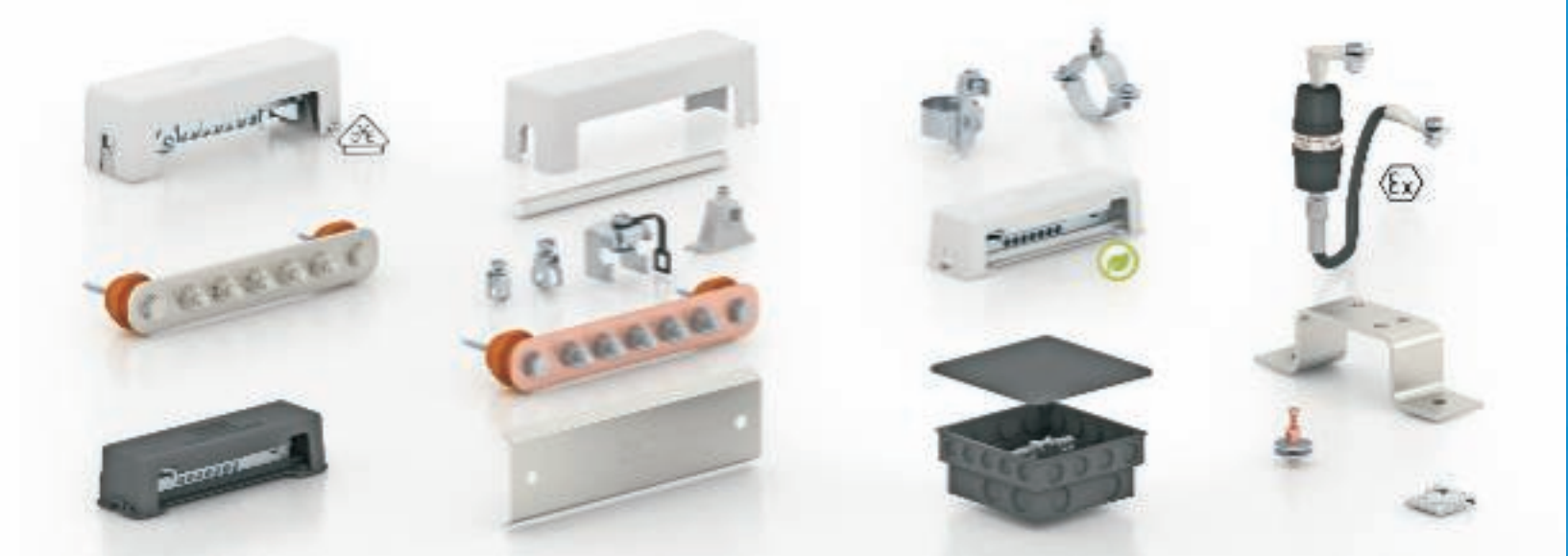

**Tested by**

- DEKRA (ATEX)
- DNV
- BET Test Centre
- VDE



14/2013 | 11 | Expo

LÖG U | sungs-katal

# Effective protection: Surge protection systems for power equipment

## Quick to react and effective

Voltage surges are caused by direct and indirect lightning strikes, and by switching operations within power networks. That is why surge protection guards not only against lightning, but also against other power line interference. Surge protection devices ensure that power lines under voltage are properly equipotentially bonded. They react before the insulation in electrical and electronic devices can be destroyed by surge voltages.

## Tested safety

All of OBO's surge protection equipment is tested in compliance with the standards in our own BET Test Centre, and comes with a five-year guarantee. A whole series of national and international test marks testify to the quality of our products.

## Tested by

- UL
- VDE
- BET Test Centre
- ÖVE
- KEMA
- GOST





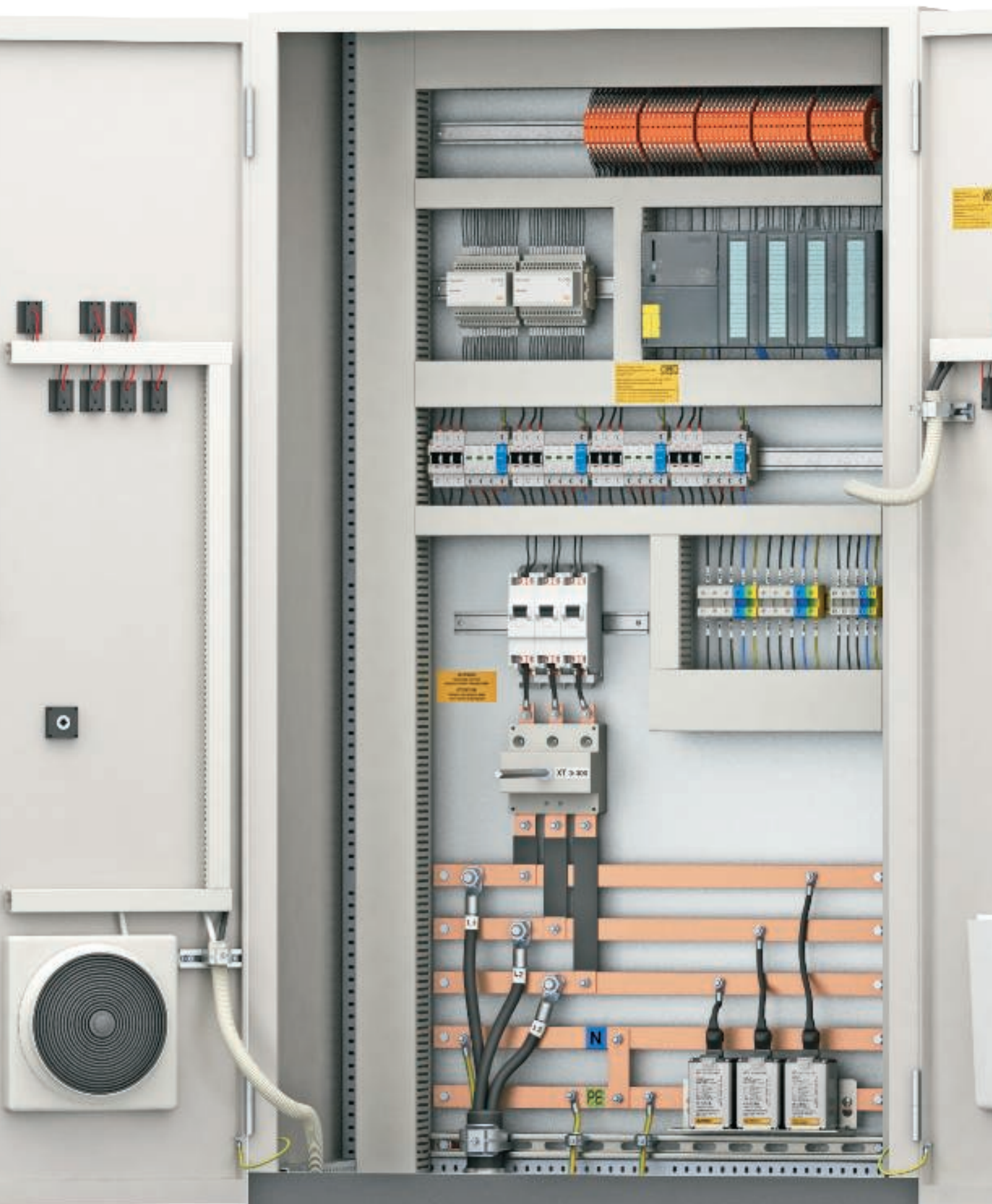

# Surge protection systems for telecommunications and data technology

## Securing the flow of data

A particularly sensitive area in chemical and petrochemical plants is that of data and communication technology. It too is strongly at risk from the impacts of lightning strikes and from surge voltages. Companies require the rapid, reliable transmission of data.

## Risk potential

Risk potentials in complex buildings can be found in their large surface area, their location and open structure, as well as in the use of modern measurement and control technology (MSR).

## Optimum protection

OBO surge protection systems offer optimum protection of the telecommunications and data cables. They react before the insulation in electrical and electronic devices is destroyed by surge voltages.

---

## Tested by

- DEKRA (ATEX)
- BET Test Centre
- Fieldbus Foundation







[www.obo-bettermann.com](http://www.obo-bettermann.com)



**OBO BETTERMANN GmbH & Co. KG**

P.O. Box 1120  
58694 Menden, Germany

**Customer Service Germany**

Tel. +49 (0)2373 89-0  
Fax +49 (0)2373 89-1238  
E-mail: [export@obo.de](mailto:export@obo.de)



# 12 LÖG Lösungskatalog\_Öl\_Gasindustrie\_2013

en

Rückseite

Back page

Stand: 3/12/2013

LLExport\_01636

Wenn LAGERLISTE:

Dann in Leaflet die Variabel "Lagerliste\_JaNein"

auf Ja

und

Alle Variablen:

5_Lagerliste_JaNein.....	Nein
Belastungsdiagramm_JaNein.....	Ja
Foto_MaxHoehe.....	0
Kundenname.....	
Kundenname_Tabellenkopf.....	
MassBild_2_JaNein.....	Nein
MassBilder_JaNein.....	Ja
Massbilder_MaxHoehe.....	30
MasstabelleBestellteil_Ja=0_Nein=100000.....	0
Masstabelle_Excel_JaNein.....	Ja
Preis_ValAID.....	
Prodbilder_Strich_Grafik.....	Grafik
Produktbilder_MaxHoehe.....	40
Rabattgruppen_JaNein.....	Nein
Schaltbild_Ja_Nein.....	Nein
StandardVPE.....	1
SystemLogo.....	
ZeileWerkstoffRabattJaNein.....	Ja
ZusAttrib_ProdText_U_Einsatzgeb_L6_Vorbelegung_721.....	0
ZusText_Grau_L7_ArtNr_Ausnahmeliste_Vorbelg_0.....	0
ZusText_GrauerHintergrund_ProdBeschrGes_Vorbelg_37.....	37
ZusText_ProdukZusatzTextHinweis_L6_Vorbelegung_222.....	66
ZusatzAttribut_L6_Wahlfrei_Vorbelegung_0.....	222
ZusatzAttribut_L7_Wahlfrei_Vorbelegung_0.....	0
ZusatzText_FussNote_L6_Vorbelegung_86.....	0
_KonformitätszeichenJaNein.....	Ja
_Preiseinheit_JaNein.....	Ja
_PrüfzeichenJaNein.....	Ja
_QualitätszeichenJaNein.....	Ja
_SchnittmarkenJaNein.....	Ja
_SpezifischeProduktsymboleJaNein.....	Nein
_nichtFuerPrintstrukturVerwenden_Ja=1Nein=0.....	1
crossAct_Farbhinterlegung_JaNein.....	nein

Katalogdatei:

Q:\2013\130832\_Loesungsbroschuere\_Oel-\_und\_Gasindustrie\_EN\04\_Temp\_Arbeitsordner\oel\_gas\_\_Katalog  
2012 2013 10 08.tsl